



(12) **United States Design Patent**  
**Miers et al.**

(10) **Patent No.:** **US D811,984 S**  
(45) **Date of Patent:** **\*\* Mar. 6, 2018**

(54) **LOADING AND UNLOADING APPARATUS FOR TRUCK BEDS**

(71) Applicants: **Casey Miers**, Houston, TX (US);  
**Kristin Miers**, Houston, TX (US)

(72) Inventors: **Casey Miers**, Houston, TX (US);  
**Kristin Miers**, Houston, TX (US)

(\*\*) Term: **15 Years**

(21) Appl. No.: **29/566,475**

(22) Filed: **May 31, 2016**

(51) **LOC (11) Cl.** ..... **12-16**

(52) **U.S. Cl.**  
USPC ..... **D12/406**

(58) **Field of Classification Search**  
USPC ..... D12/221, 400, 401, 412, 317, 406, 414,  
D12/175, 176, 177, 197, 199, 201, 202,  
D12/204, 212; D34/16, 23, 28, 34, 35,  
D34/38, 21, 22, 24  
CPC ..... A01B 1/00; B60P 1/00; B65G 7/12  
See application file for complete search history.

(56) **References Cited**

**U.S. PATENT DOCUMENTS**

D265,007 S *	6/1982	Cuta	.....	D32/49
D288,276 S *	2/1987	Harney	.....	294/15
D349,437 S *	8/1994	Mock	.....	294/15
6,109,362 A *	8/2000	Simpson, Sr.	.....	A01B 1/00 172/375
6,186,566 B1 *	2/2001	Frederickson	.....	B65G 7/12 294/15
6,478,352 B1 *	11/2002	Fredrickson	.....	B65G 7/12 294/15
6,520,555 B1 *	2/2003	Hamm	.....	B65G 7/12 294/15
7,334,825 B1	2/2008	Sammon	.....	

D570,574 S *	6/2008	Liebenstein	.....	D34/28
D581,125 S *	11/2008	Barone	.....	D34/28
D600,424 S *	9/2009	Pouliot	.....	D34/28
7,980,608 B2	7/2011	Pouliot et al.	.....	
D703,014 S *	4/2014	Lohmann	.....	D8/13
D786,518 S *	5/2017	Szekely	.....	D32/35
2010/0034629 A1	2/2010	Hamann	.....	
2015/0083346 A1 *	3/2015	Miers	.....	B60P 1/00 160/127

\* cited by examiner

*Primary Examiner* — Karen S Acker

*Assistant Examiner* — Jerry Shiuuan-Hua Hsu

(74) *Attorney, Agent, or Firm* — Buche & Associates,  
P.C.; John K. Buche; Scott D. Compton

(57) **CLAIM**

The ornamental design for a loading and unloading apparatus for truck beds, as shown and described.

**DESCRIPTION**

FIG. 1 is a front perspective view of a loading and unloading apparatus for truck beds, showing our new design; FIG. 2 is front view thereof; FIG. 3 is rear view thereof; FIG. 4 is right side view thereof where the left side view is a mirror image; FIG. 5 is top view thereof; FIG. 6 is bottom view thereof; and, FIG. 7 is front perspective view thereof; showing the article in a state of use.

The broken lines illustrating a truck bed in FIG. 7 represent environmental subject matter that forms no part of the claim. All other broken lines illustrate portions of the loading and unloading apparatus for truck beds that form no part of the claimed design.

**1 Claim, 5 Drawing Sheets**

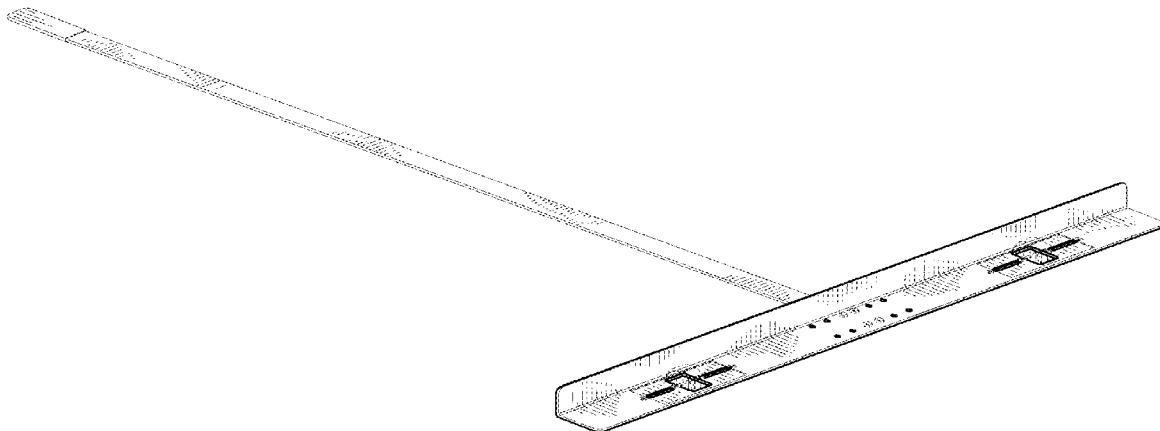

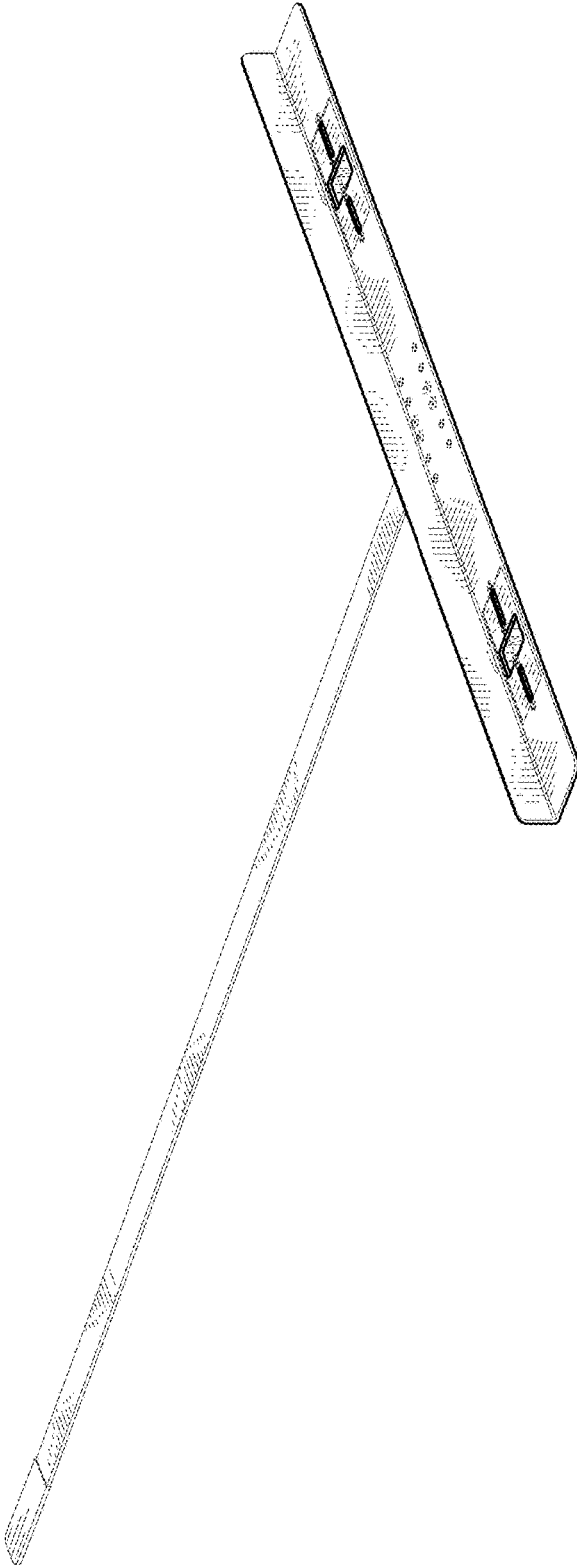

FIG. 1

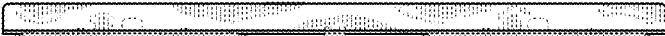

FIG. 2



FIG. 3



FIG. 4

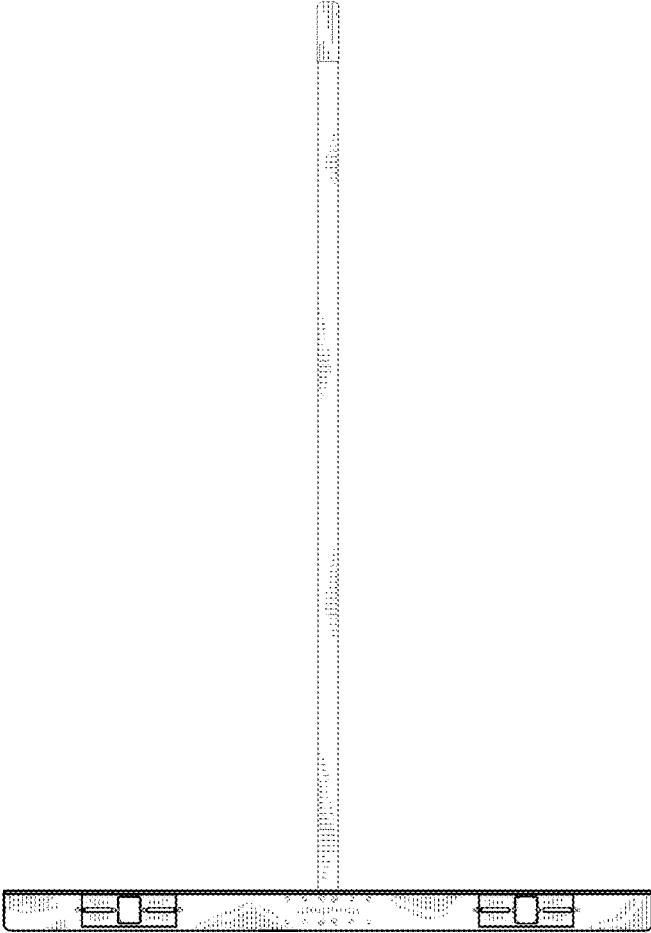

FIG. 5

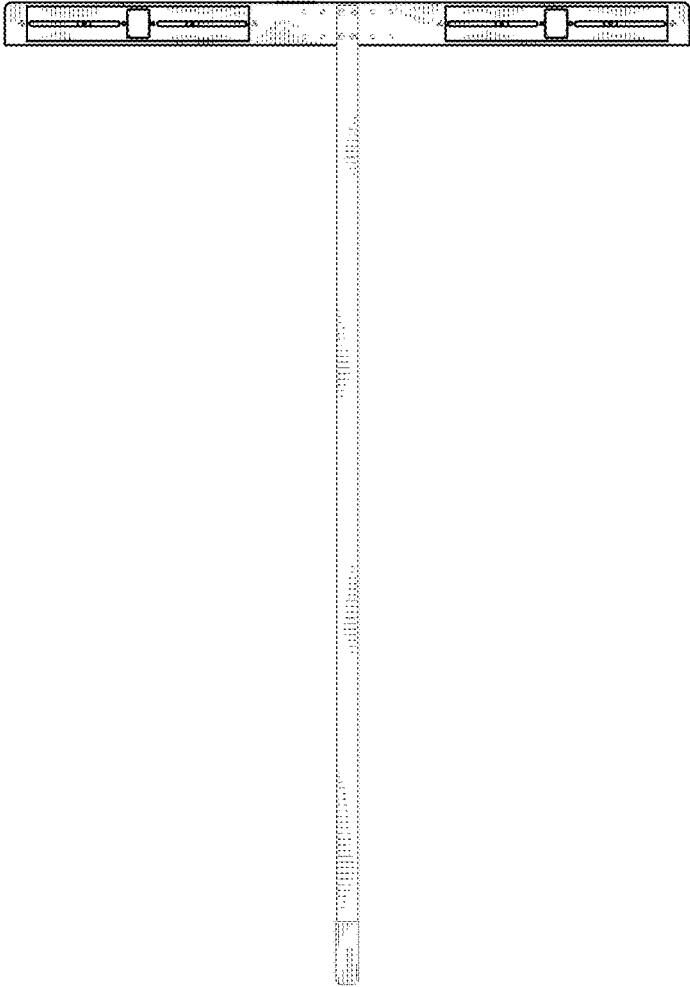

FIG. 6

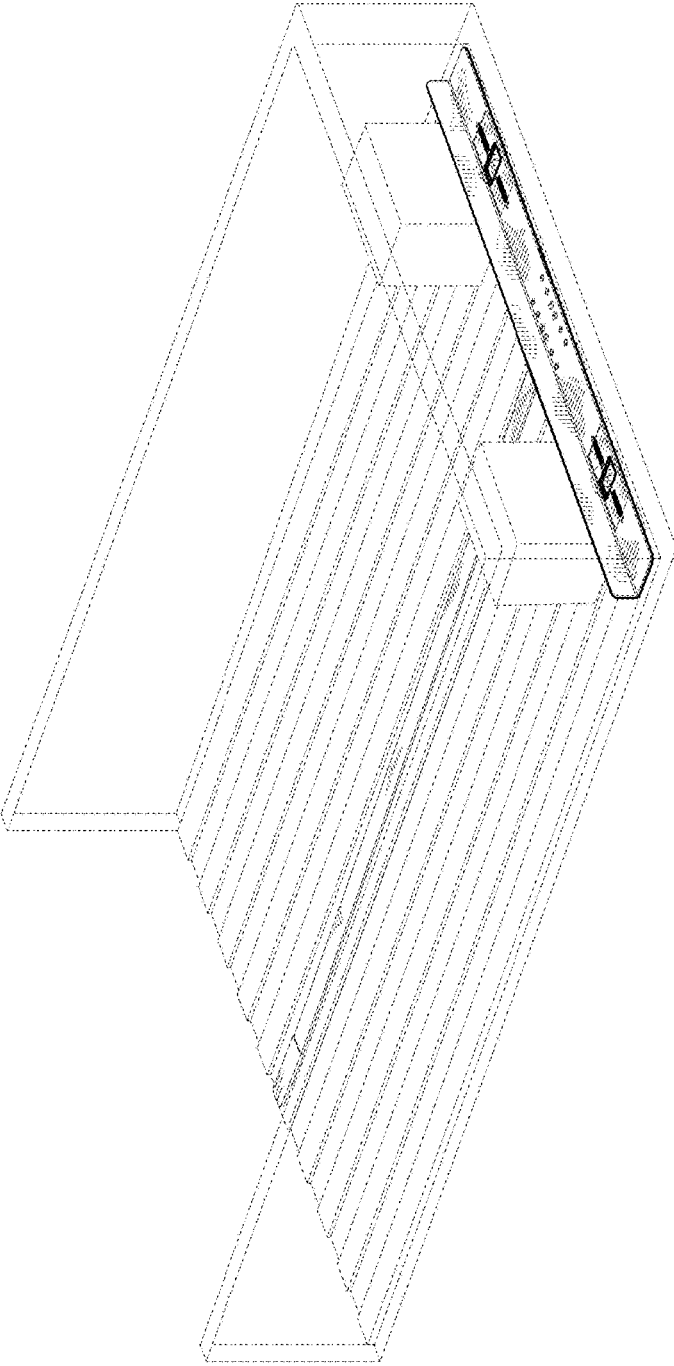

FIG. 7